



Contents

Contents ..... 1

Important note ..... 2

Control elements ..... 3

Rear panel features introduction ..... 4

Rear panel features introduction ..... 5

Audio input and output connections ..... 6

    Output Mode ..... 7

Professional Power Amplifier Specifications ..... 8



## Important Note

### **WARNING NOTICES**

#### **SAFEGUARDS**

Electrical energy can perform many useful functions. This unit has been engineered and manufactured to assure your personal safety. Improper use can result in potential electrical shock or fire hazards. In order not to defeat the safeguards, observe the following precautions for its installation, use and servicing.

#### **Explanation of Graphical Symbols**

  
**CAUTION**  
**RISK OF ELECTRIC SHOCK**  
**DO NOT OPEN**

  
**CAUTION**  
**RISK OF ELECTRIC SHOCK:**  
**OPEN ONLY BY QUALIFIED**  
**SERVICE PERSONNEL**

**WARNING: TO PREVENT FIRE OR ELECTRIC SHOCK, DO NOT EXPOSE THIS EQUIPMENT TO RAIN OR MOISTURE**

#### **IMPORTANT NOTE**

ATTENTION: This unit must be protected from damp because of the risk of fire and the possibility of electric shocks.

1. Make sure that you have the correct mains voltage. Only operate the unit at the mains voltage marked on the rear panel.
2. Make sure that nothing especially no metal objects are inserted into the device. This could result in electric shock or malfunction.
3. If the unit is subjected to extreme fluctuations of temperature e.g. On being transported from outside into a heated room, condensation can form. This unit should not be used until it has reached room temperature.
4. In the event of water or any other fluid being accidentally spilt on the unit switch the unit off immediately and send it to a qualified service workshop for inspection.
5. Make sure that the unit is always well ventilated and never exposed to direct sunlight.
6. Do not use sprays to clean the unit as they have a detrimental effect on the unit and could ignite suddenly.
7. The machine use single power switch, please cut off the power before fix.
8. Please do not put the cup, vessel of flower or container above the machine, in case the leak out water then cause the leakage current off the machine.

Control elements

**Front Panel**

The front panel LED area includes the following indicators per channel:



**1. LEVEL CONTROL**

Calibrated detente potentiometers to alter the total gain of the power amplifier. In order to avoid distortions in mixing consoles upstream, these controls should normally be positioned between 0 and 10. The calibrated markings show the additional attenuation directly.

**2. PROTECT LED**

protection under mute position.

**3. CLIP/LIMIT INDICATOR**

This indicator signals if the amplifier output is clipping or limiting. It has two different indication states: If the clip limiter is engaged, it illuminates briefly. If the clip limiter is not engaged, it illuminates for a longer period.

**4. SIGNAL LED**

Green SIG Indicates output signal levels in normal operating range.

**5. TEMP**

This LED lights up if the limiter has been activated and the power amplifier is being operated at the clip level. If the LED flashes briefly, this is not a cause for concern. If this LED is lit permanently, the volume should be reduced to avoid overload damages to the connected loudspeaker systems.

**6. VHF**

VHF - Very High Frequency protection active (output muted) (Yellow Constant).

**7. CPL LED**

CPL - (Orange constant with output muted): Low impedance / Short Circuit Detection Fault.

**8. POWER SWITCH**

Turn the unit power on or off.

Rear panel features introduction

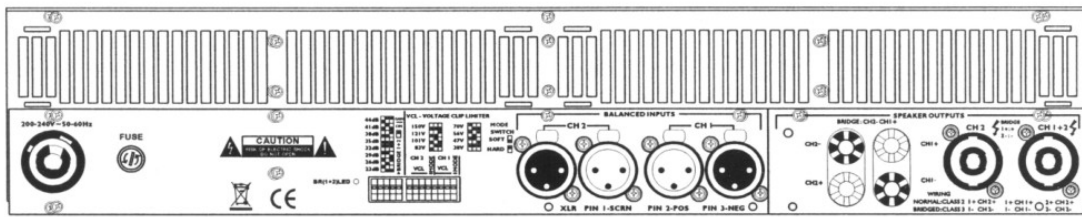
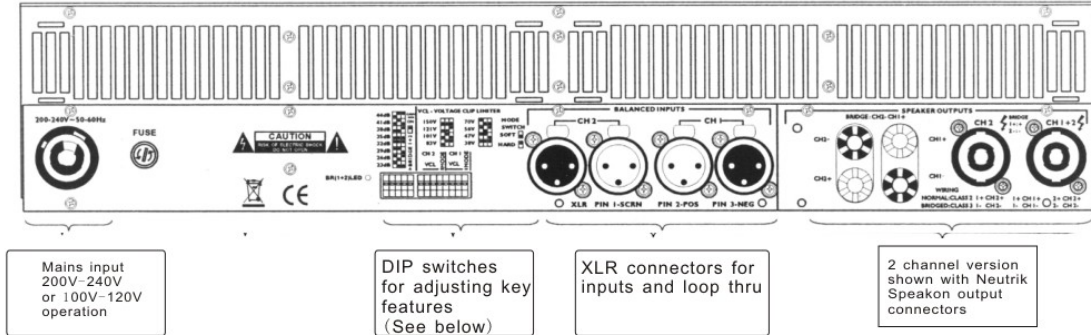

Rear view of 2-channel model fitted with Speakon Connectors



Two-channel model shown. Two-channel versions have VCL and Bridge Mode switches for channel 1 and 2 only. All models have different VCL values. Functions are otherwise identical.

44dB 41dB 38dB 35dB 32dB 29dB 26dB 23dB	GAIN ON OFF BRIDGE 1+2	<b>VCL - VOLTAGE CLIP LIMITER</b>			
		195V	100V	MODE SWITCH	
		170V	80V	SOFT	
		140V	66V	HARD	
		116V	54V		
		CH 2	CH 1		
VCL	IMODE	VCL	IMODE		

6.2.2 The DIP switch features

The following features may be adjusted using the DIP switches on the rear-panel of the amplifier. Gain - Globally set for all channels, from +23 dB to +44 dB in 3 dB steps.

Bridge 1+2 Switches the channel pairs into bridge mode operation. An automatic -6 dB gain compensation is applied.

Rear panel features introduction

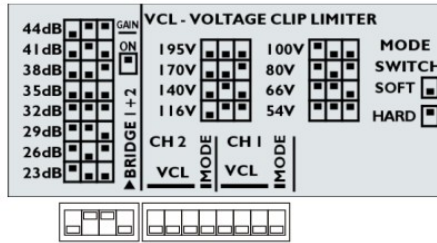

**VCL-Voltage Clip Limiter** adjustment is provided for eight discrete levels for each channel. Select the setting most appropriate for connected speakers.

**Mode-Select VCL mode** to either Hard or Soft operation. For channels driving sub-woofers and low-frequency drivers, it is recommended to use the Hard setting for optimal operation. For mid- and high-frequency drivers, always select Soft.

Output connectors

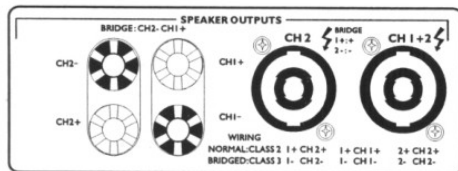

Speakon outputs-2-channel models

Input or output connectors

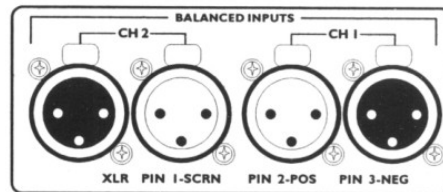

Audio inputs or ouput-2-channel models

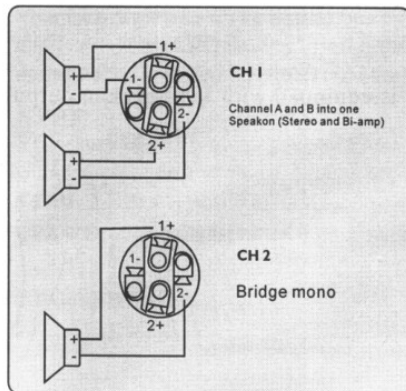

**Two-channel amplifiers** Additional connectors are provided for Channel 1.

Audio input and output connections

BALANCED INPUT CONNECTIONS

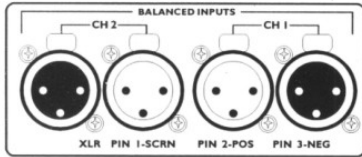

Audio input-2-channel models

The XLR input connectors are electronically balanced, and wired according to the IEC 268 standard ( pin 2= hot ). XLR input connectors should be wired as follows:

- Pin 1 Ground/Shield
- Pin 2 Hot (+)
- Pin 3 Cold (-)

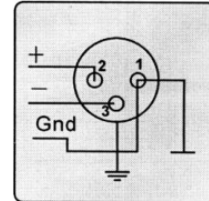

When linking the same source signal to several input channels, be aware that there is a limit to the number of channels an output source can "drive". A typical output source (e.g. a DSP crossover unit) can drive up to two amplifier channels before external line-drivers might be required to buffer the signal.

Unbalanced Input connections

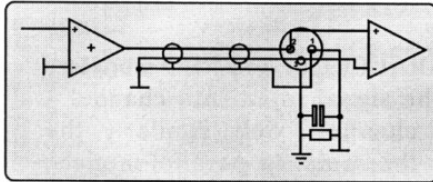

To connect an input to an unbalanced source, it is possible to connect pins 1 and 3 in the XLR plug at the amplifier end of the cable. However, a better method is to connect pin 3 to the shield at the source end of the cable, as this usually results in better hum and noise rejection. Balanced input connections are recommended whenever possible.

Speakon Output connections

Refer to the instructions in this section if your amplifier is equipped with the Speakon output connectors

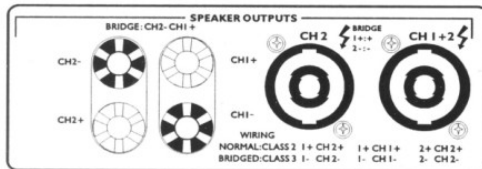

Output Mode

Stereo Mode

Before setting the mode, please turn off the amplifier and slide the mode select switch to below (Picture 1). In this mode, Channel 1 and Channel 2 operate independently (Just traditional stereo amplifier). The signal input into channel 1 can be output from channel 1 only, similarly, the signal input into channel 2 can be output from channel 2 only. The many channels, one by one in order type pushes.

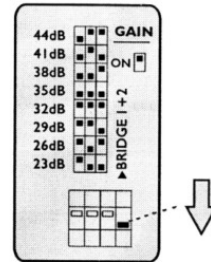

(Picture 1)

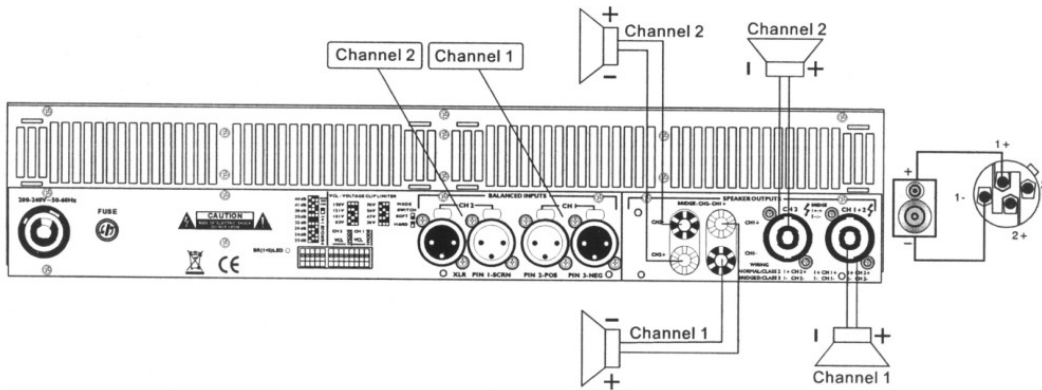

Bridge Mode

Before setting the mode, please turn off the amplifier and slide the mode select switch to above (Picture 2), channel 1 and channel 2 are bridged. At this time, the signal input into channel 1 will be output from the bridge end. On the other hand, the output level control of channel 2 should be turned down to smallest. Only the volume control of channel 1 are used to control the volume of the whole system.

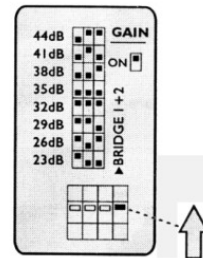

(Picture 2)

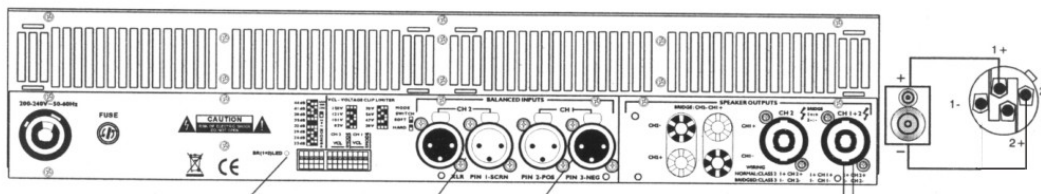



## Professional Power Amplifier Specifications

Model	HA3400	HA6400	HA7K	HA9k	HA13K	HA14K
8 $\Omega$ Stereo Power	2×1100W	2×1300W	2×1450W	2×1600W	2×2350W	2×2350W
4 $\Omega$ Stereo Power	2×1500W	2×2300W	2×2800W	2×3000W	2×4400W	2×4400W
2 $\Omega$ Stereo Power	2×1700W	2×2900W	2×3500W	2×4500W	2×6500W	2×7000W
8 $\Omega$ Bridged Power	3000W	4600W	5600W	6000W	8800W	8800W
4 $\Omega$ Bridged Power	3400W	5800W	7000W	9000W	13000W	14000W

<b>FREQUENCY RESPONSE</b>	20Hz-25kHz $\pm$ 0.5dB
<b>THD+N (Rated power, 4<math>\Omega</math>/1KHz)%</b>	0.10%
<b>Signal Noise Ration (dB)</b>	110dB
<b>Input Impedance</b>	20K $\Omega$ Balanced / 10K $\Omega$ Unbalanced
<b>Amplifier gain selectable (All channels)-rear-panel switches</b>	23, 26, 29, 32, 35, 38, 41, 44dB
<b>Output Connectors</b>	Speakon Connectors (NEUTRIK)
<b>Power Requirement</b>	100-120V-50-60Hz or 200-240V-50-60Hz

<b>Dimension</b>	
<b>Airframe</b>	483×377×88mm
<b>Weight</b>	
<b>Weight(net)</b>	13Kg

Haozhiseng Audio

ADD: Room C3585, 3rd Floor, No. 22, Lane 7, Yongtai Zhihe Street, Yongping Street, Baiyun District, Guangzhou, China

**www.hzsaudio.com**